

Dual, Low Power INSTRUMENTATION AMPLIFIER

FEATURES

- **LOW OFFSET VOLTAGE:** 50µV max
- **LOW DRIFT:** 0.5µV/°C max
- **LOW INPUT BIAS CURRENT:** 5nA max
- **HIGH CMR:** 120dB min
- **INPUTS PROTECTED TO ±40V**
- **WIDE SUPPLY RANGE:** ±2.25V to ±18V
- **LOW QUIESCENT CURRENT:** 700µA / IA
- **16-PIN PLASTIC DIP, SOL-16**

APPLICATIONS

- **SENSOR AMPLIFIER**
THERMOCOUPLE, RTD, BRIDGE
- **MEDICAL INSTRUMENTATION**
- **MULTIPLE-CHANNEL SYSTEMS**
- **BATTERY OPERATED EQUIPMENT**

DESCRIPTION

The INA2128 is a dual, low power, general purpose instrumentation amplifier offering excellent accuracy. Its versatile 3-op amp design and small size make it ideal for a wide range of applications. Current-feedback input circuitry provides wide bandwidth even at high gain (200kHz at G = 100).

A single external resistor sets any gain from 1 to 10,000. Internal input protection can withstand up to ±40V without damage.

The INA2128 is laser-trimmed for very low offset voltage (50µV), drift (0.5µV/°C) and high common-mode rejection (120dB at G ≥ 100). It operates with power supplies as low as ±2.25V, and quiescent current is only 700µA per IA—ideal for battery-operated and multiple-channel systems.

The INA2128 is available in SOL-16 packages, specified for the –40°C to +85°C temperature range.

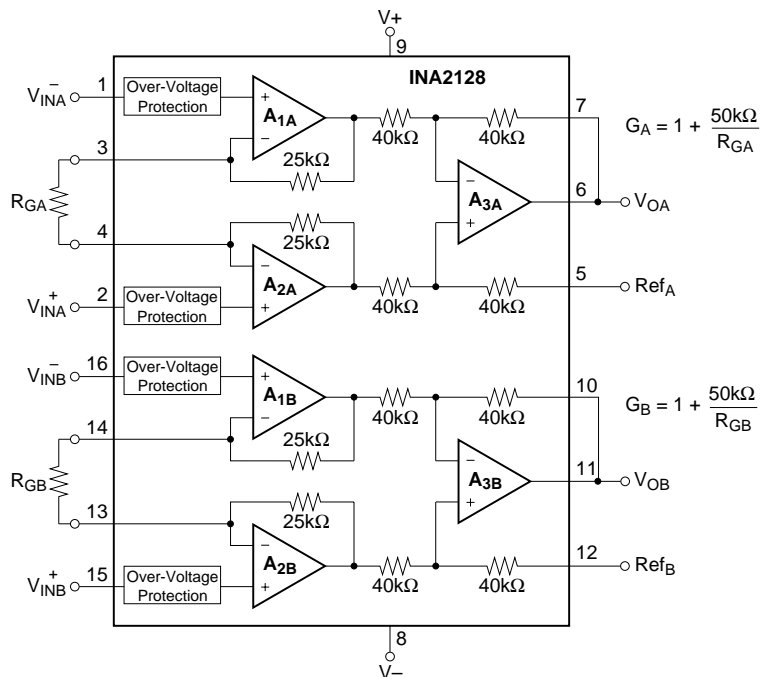

Please be aware that an important notice concerning availability, standard warranty, and use in critical applications of Texas Instruments semiconductor products and disclaimers thereto appears at the end of this data sheet.

All trademarks are the property of their respective owners.

ABSOLUTE MAXIMUM RATINGS⁽¹⁾

Supply Voltage	±18V
Analog Input Voltage Range	±40V
Output Short-Circuit (to ground)	Continuous
Operating Temperature	-40°C to +125°C
Storage Temperature	-55°C to +125°C
Junction Temperature	+150°C

NOTE: (1) Stresses above these ratings may cause permanent damage. Exposure to absolute maximum conditions for extended periods may degrade device reliability.

PIN CONFIGURATION

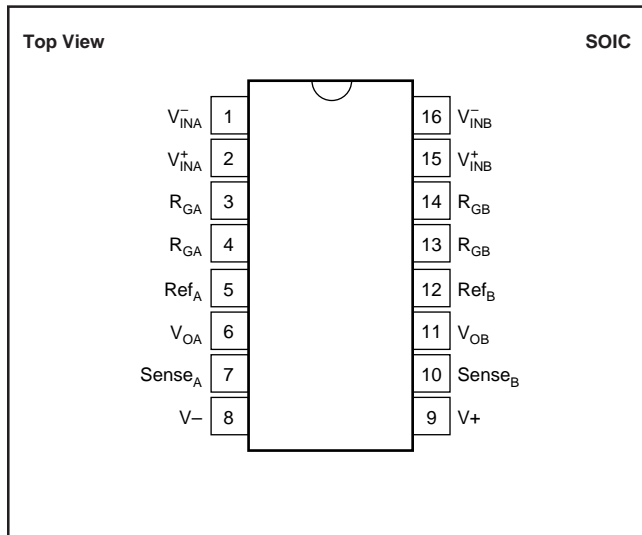

ELECTROSTATIC DISCHARGE SENSITIVITY

This integrated circuit can be damaged by ESD. Texas Instruments recommends that all integrated circuits be handled with appropriate precautions. Failure to observe proper handling and installation procedures can cause damage.

ESD damage can range from subtle performance degradation to complete device failure. Precision integrated circuits may be more susceptible to damage because very small parametric changes could cause the device not to meet its published specifications.

ORDERING INFORMATION⁽¹⁾

PRODUCT	PACKAGE-LEAD	PACKAGE DESIGNATOR	TEMPERATURE RANGE
INA2128UA	SOIC-16	DW	-40°C to +85°C
INA2128U	SOIC-16	DW	-40°C to +85°C

NOTES: (1) For the most current package and ordering information, see the Package Option Addendum at the end of this document, or see the TI web site at www.ti.com.

ELECTRICAL CHARACTERISTICS

At $T_A = +25^\circ\text{C}$, $V_S = \pm 15\text{V}$, $R_L = 10\text{k}\Omega$, unless otherwise noted.

PARAMETER	CONDITIONS	INA2128U			INA2128UA			UNITS
		MIN	TYP	MAX	MIN	TYP	MAX	
INPUT								
Offset Voltage, RTI								
Initial	$T_A = +25^\circ\text{C}$		$\pm 10 \pm 100/\text{G}$	$\pm 50 \pm 500/\text{G}$		$\pm 25 \pm 100/\text{G}$	$\pm 125 \pm 1000/\text{G}$	μV
vs Temperature	$T_A = T_{\text{MIN}}$ to T_{MAX}		$\pm 0.2 \pm 2/\text{G}$	$\pm 0.5 \pm 20/\text{G}$		$\pm 0.2 \pm 5/\text{G}$	$\pm 1 \pm 20/\text{G}$	$\mu\text{V}/^\circ\text{C}$
vs Power Supply	$V_S = \pm 2.25\text{V}$ to $\pm 18\text{V}$		$\pm 0.2 \pm 20/\text{G}$	$\pm 1 \pm 100/\text{G}$		*	$\pm 2 \pm 200/\text{G}$	$\mu\text{V}/\text{V}$
Long-Term Stability			$\pm 0.1 \pm 3/\text{G}$			*		$\mu\text{V}/\text{mo}$
Impedance, Differential			$10^{10} \parallel 2$			*		$\Omega \parallel \text{pF}$
Common-Mode			$10^{11} \parallel 9$			*		$\Omega \parallel \text{pF}$
Common-Mode Voltage Range ⁽¹⁾	$V_O = 0\text{V}$	$(V+) - 2$ $(V-) + 2$	$(V+) - 1.4$ $(V-) + 1.7$		*	*		V
Safe Input Voltage				± 40			*	V
Common-Mode Rejection	$V_{\text{CM}} = \pm 13\text{V}$, $\Delta R_S = 1\text{k}\Omega$						*	V
	$G=1$	80	86		73	*		dB
	$G=10$	100	106		93	*		dB
	$G=100$	120	125		110	*		dB
	$G=1000$	120	130		110	*		dB
BIAS CURRENT								
vs Temperature			± 2	± 5		*	± 10	nA
Offset Current			± 30			*		$\text{pA}/^\circ\text{C}$
vs Temperature			± 1	± 5		*	± 10	nA
			± 30			*		$\text{pA}/^\circ\text{C}$
NOISE VOLTAGE, RTI								
$f = 10\text{Hz}$	$G = 1000$, $R_S = 0\Omega$		10			*		$\text{nV}/\sqrt{\text{Hz}}$
$f = 100\text{Hz}$			8			*		$\text{nV}/\sqrt{\text{Hz}}$
$f = 1\text{kHz}$			8			*		$\text{nV}/\sqrt{\text{Hz}}$
$f_B = 0.1\text{Hz}$ to 10Hz			0.2			*		μV_{PP}
Noise Current								
$f=10\text{Hz}$			0.9			*		$\text{pA}/\sqrt{\text{Hz}}$
$f=1\text{kHz}$			0.3			*		$\text{pA}/\sqrt{\text{Hz}}$
$f_B = 0.1\text{Hz}$ to 10Hz			30			*		pA_{PP}
GAIN								
Gain Equation			$1 + (50\text{k}\Omega/R_G)$			*		V/V
Range of Gain		1		10000	*		*	V/V
Gain Error	$G=1$		± 0.01	± 0.024		*	± 0.1	%
	$G=10$		± 0.02	± 0.4		*	± 0.5	%
	$G=100$		± 0.05	± 0.5		*	± 0.7	%
	$G=1000$		± 0.5	± 1		*	± 2	%
Gain vs Temperature ⁽²⁾	$G=1$		± 1	± 10		*	*	$\text{ppm}/^\circ\text{C}$
50k Ω Resistance ^(2, 3)			± 25	± 100		*	*	$\text{ppm}/^\circ\text{C}$
Nonlinearity	$V_O = \pm 13.6\text{V}$, $G=1$		± 0.0001	± 0.001		*	± 0.002	% of FSR
	$G=10$		± 0.0003	± 0.002		*	± 0.004	% of FSR
	$G=100$		± 0.0005	± 0.002		*	± 0.004	% of FSR
	$G=1000$		± 0.001	(Note 4)		*	*	% of FSR
OUTPUT								
Voltage: Positive	$R_L = 10\text{k}\Omega$	$(V+) - 1.4$	$(V+) - 0.9$		*	*		V
Negative	$R_L = 10\text{k}\Omega$	$(V-) + 1.4$	$(V-) + 0.8$		*	*		V
Load Capacitance Stability			1000			*		pF
Short-Circuit Current			$+6/-15$			*		mA
FREQUENCY RESPONSE								
Bandwidth, -3dB	$G=1$		1.3			*		MHz
	$G=10$		700			*		kHz
	$G=100$		200			*		kHz
	$G=1000$		20			*		kHz
Slew Rate	$V_O = \pm 10\text{V}$, $G=10$		4			*		V/ μs
Settling Time, 0.01%	$G=1$		7			*		μs
	$G=10$		7			*		μs
	$G=100$		9			*		μs
	$G=1000$		80			*		μs
Overload Recovery	50% Overdrive		4			*		μs
POWER SUPPLY								
Voltage Range		± 2.25	± 15	± 18	*	*	*	V
Current, Total	$V_{\text{IN}} = 0\text{V}$		± 1.4	± 1.5		*	*	mA
TEMPERATURE RANGE								
Specification		-40		85	*		*	$^\circ\text{C}$
Operating		-40		125	*		*	$^\circ\text{C}$
θ_{JA}			80			*		$^\circ\text{C}/\text{W}$

* Specification same as INA2128P, U.

NOTE: (1) Input common-mode range varies with output voltage—see Electrical Characteristics.

(2) Ensured by wafer test.

(3) Temperature coefficient of the 50k Ω term in the gain equation.

(4) Nonlinearity measurements in $G = 1000$ are dominated by noise. Typical nonlinearity is $\pm 0.001\%$.

TYPICAL CHARACTERISTICS

At $T_A = +25^\circ\text{C}$, $V_S = \pm 15\text{V}$, unless otherwise noted.

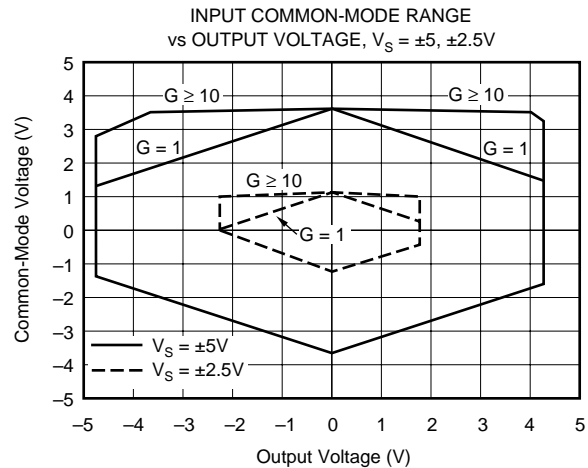
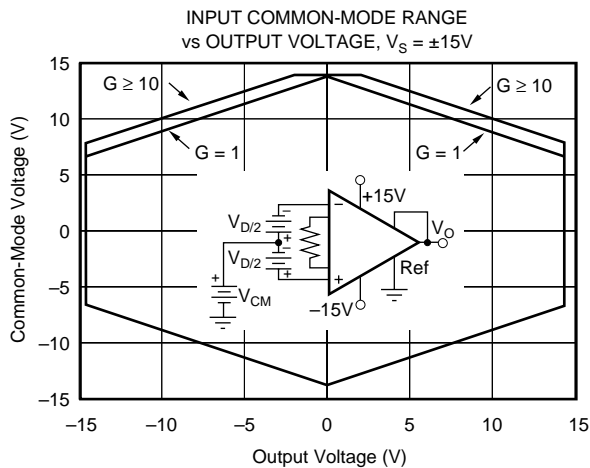
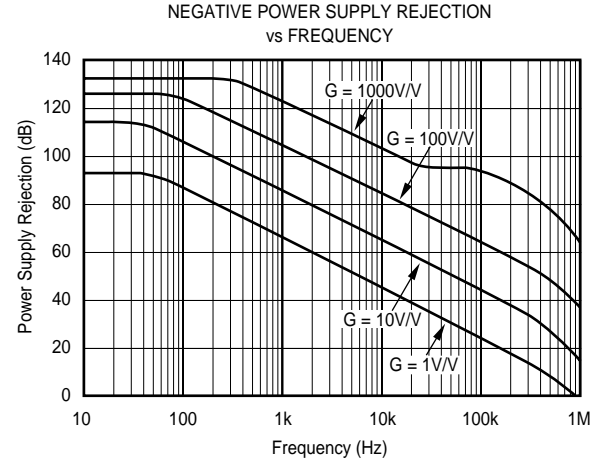
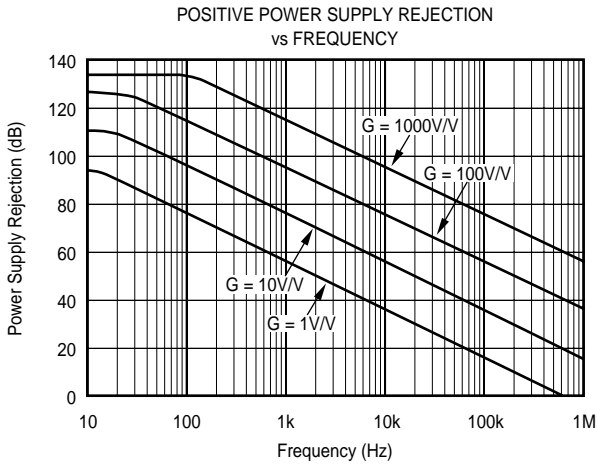
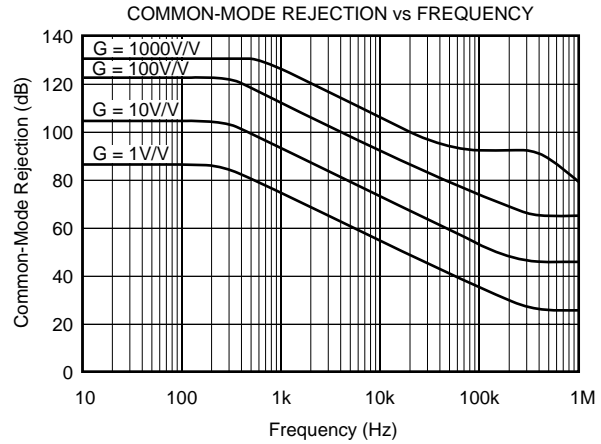
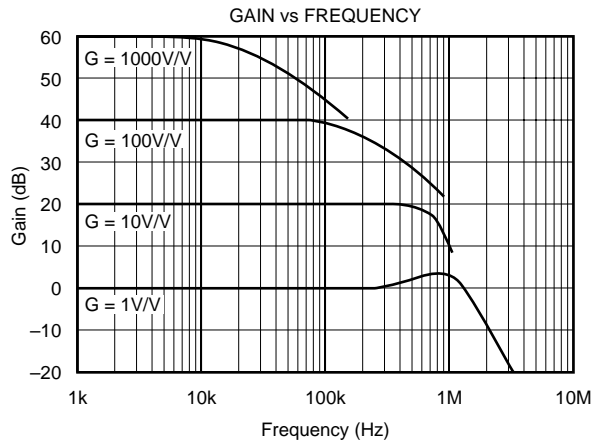

TYPICAL CHARACTERISTICS (Continued)

At $T_A = +25^\circ\text{C}$, $V_S = \pm 15\text{V}$, unless otherwise noted.

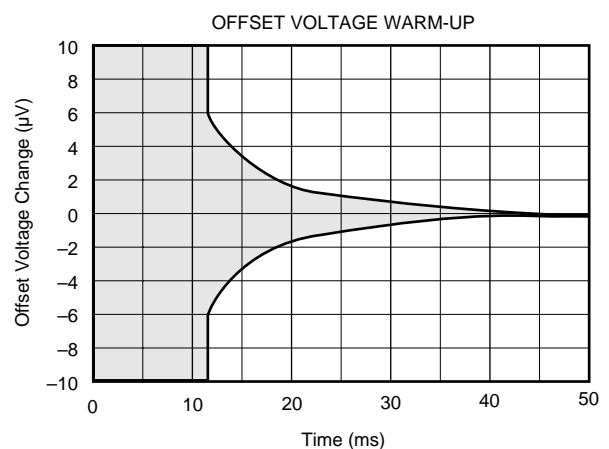
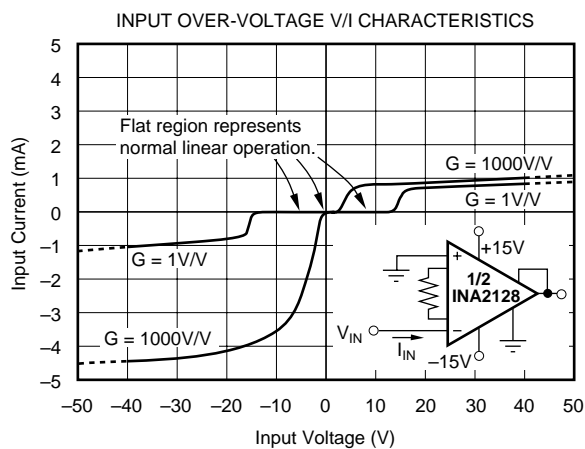
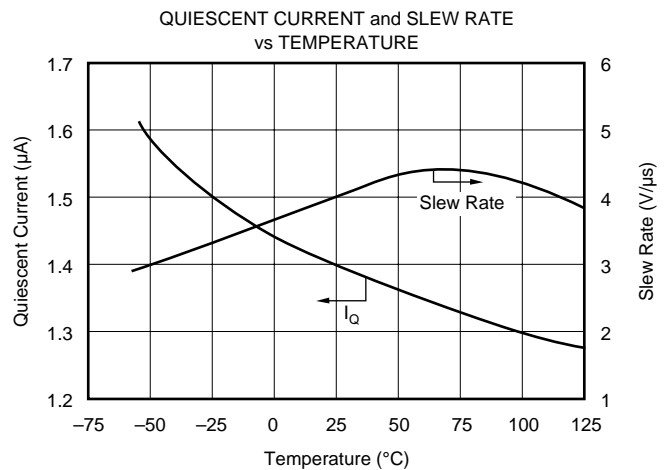
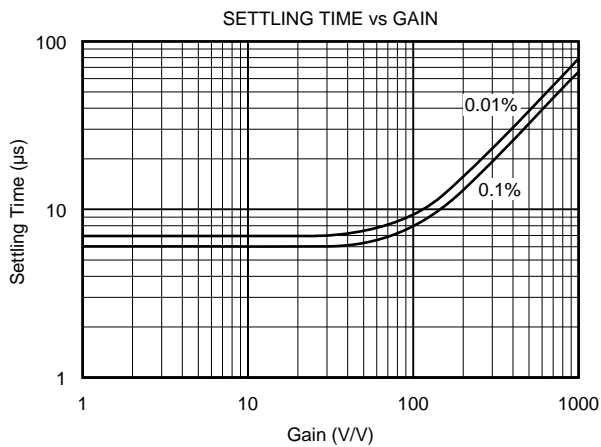
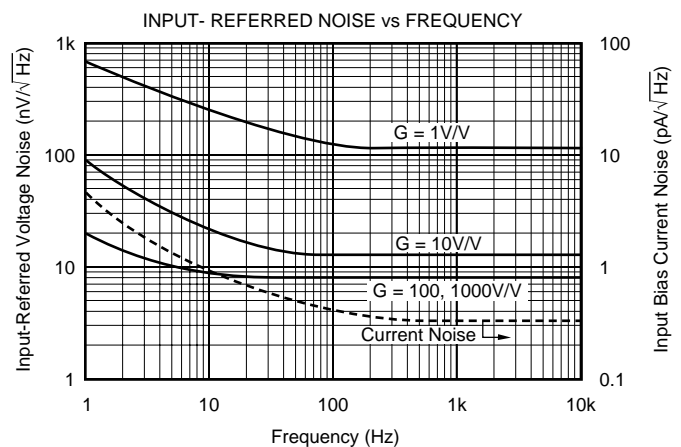
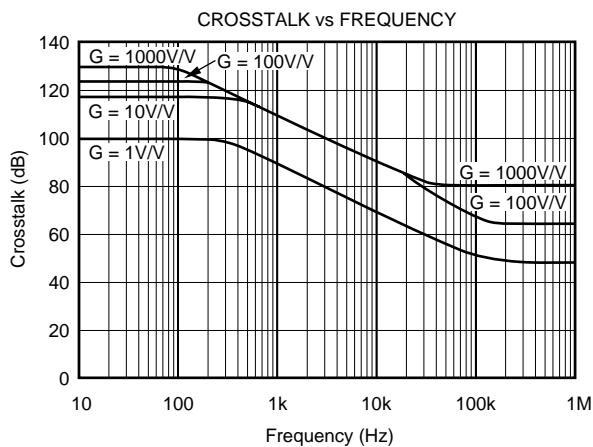

TYPICAL CHARACTERISTICS (Continued)

At $T_A = +25^\circ\text{C}$, $V_S = \pm 15\text{V}$, unless otherwise noted.

INPUT BIAS CURRENT vs TEMPERATURE

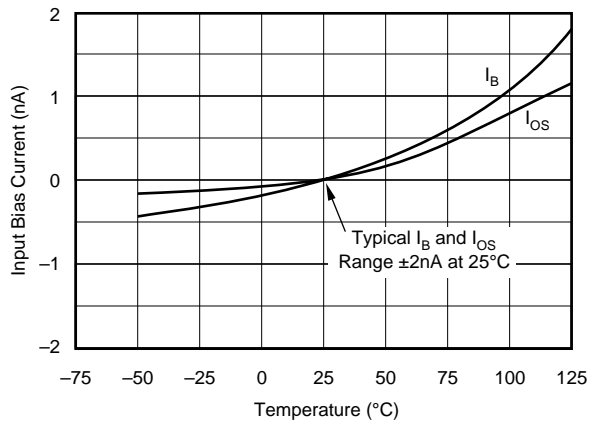

OUTPUT VOLTAGE SWING vs OUTPUT CURRENT

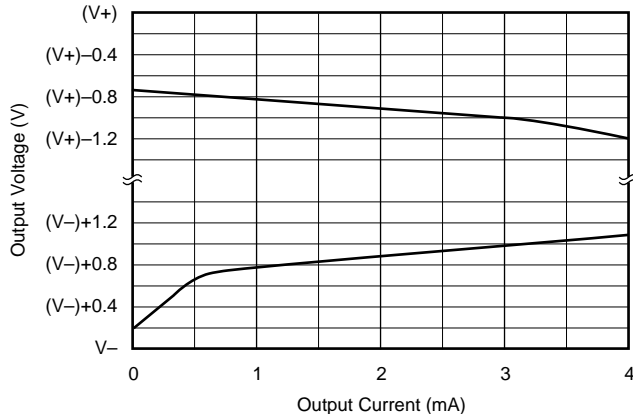

OUTPUT VOLTAGE SWING vs POWER SUPPLY VOLTAGE

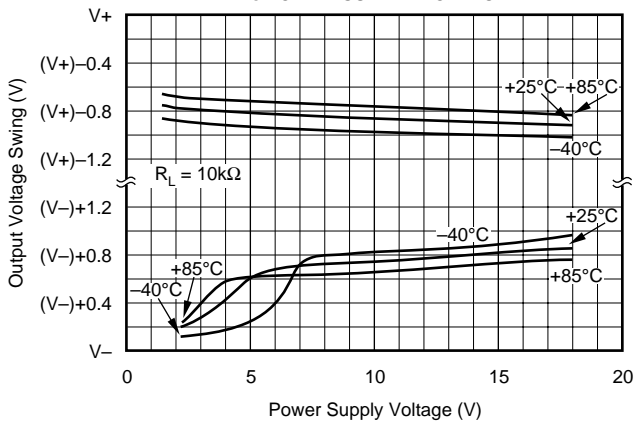

SHORT-CIRCUIT OUTPUT CURRENT vs TEMPERATURE

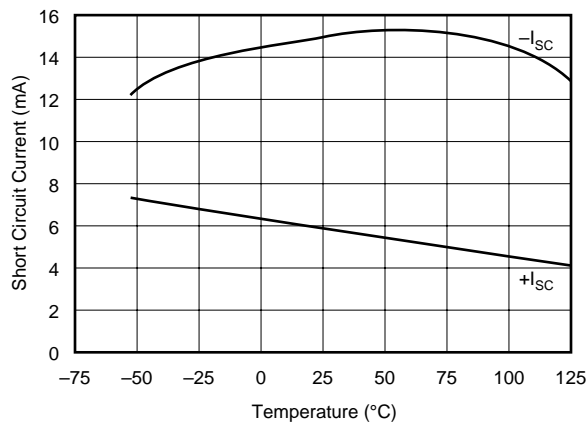

MAXIMUM OUTPUT VOLTAGE vs FREQUENCY

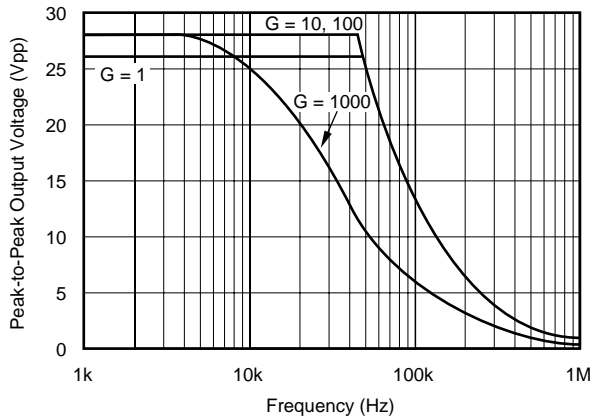

TOTAL HARMONIC DISTORTION + NOISE vs FREQUENCY

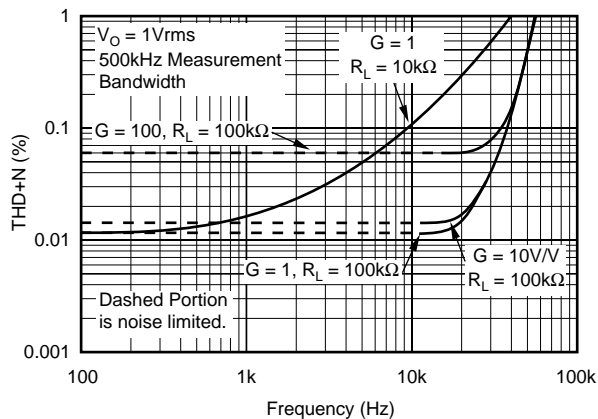

TYPICAL CHARACTERISTICS (Continued)

At $T_A = +25^\circ\text{C}$, $V_S = \pm 15\text{V}$, unless otherwise noted.

SMALL-SIGNAL STEP RESPONSE
(G = 1, 10)

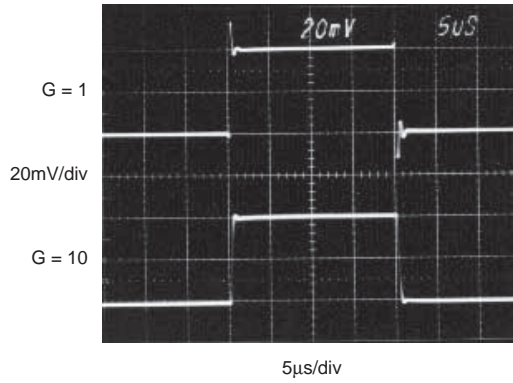

SMALL-SIGNAL STEP RESPONSE
(G = 100, 1000)

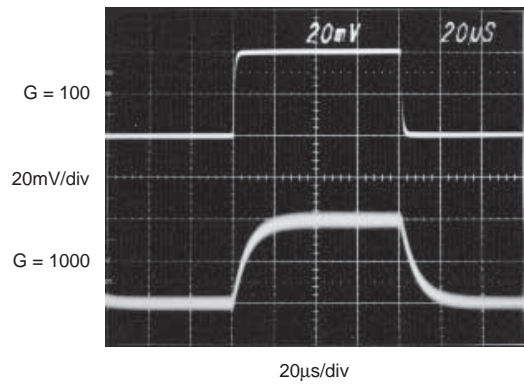

LARGE-SIGNAL STEP RESPONSE
(G = 1, 10)

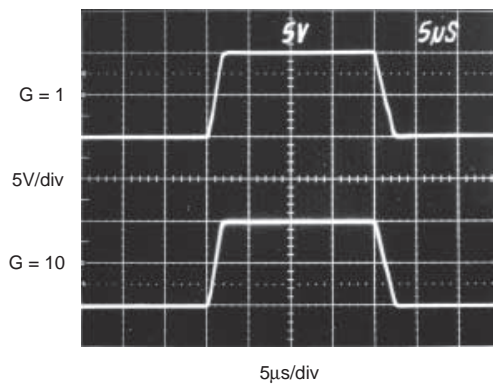

LARGE-SIGNAL STEP RESPONSE
(G = 100, 1000)

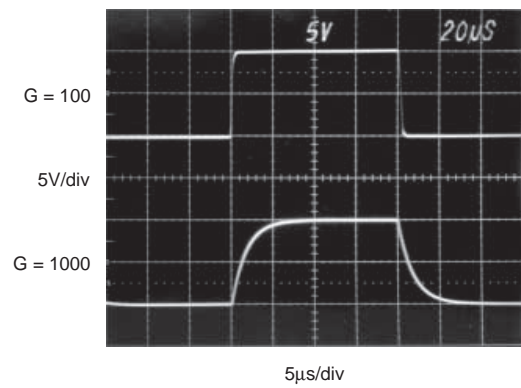

VOLTAGE NOISE 0.1Hz to 10Hz
INPUT-REFERRED, $G \geq 100$

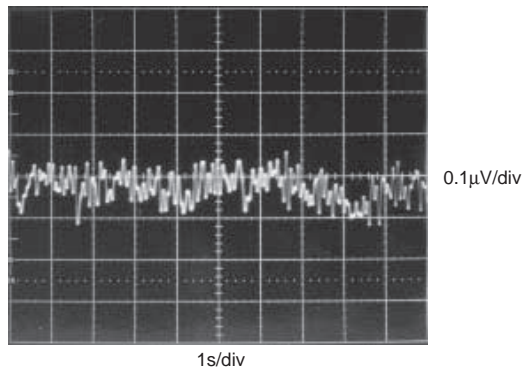

APPLICATION INFORMATION

Figure 1 shows the basic connections required for operation of the INA2128. Applications with noisy or high impedance power supplies may require decoupling capacitors close to the device pins as shown.

The output is referred to the output reference (Ref) terminals (Ref_A and Ref_B) which are normally grounded. These must be low-impedance connections to assure good common-mode rejection. A resistance of 8Ω in series with a Ref pin will cause a typical device to degrade to approximately 80dB CMR (G = 1).

The INA2128 has separate output sense feedback connections, Sense_A and Sense_B. These must be connected to their respective output terminals for proper operation. The output sense connection can be used to sense the output voltage directly at the load for best accuracy.

SETTING THE GAIN

Gain of the INA2128 is set by connecting a single external resistor, R_G, connected as shown:

$$G = 1 + \frac{50k\Omega}{R_G} \quad (1)$$

Commonly-used gains and resistor values are shown in Figure 1.

The 50kΩ term in Equation 1 comes from the sum of the two

internal feedback resistors, A₁ and A₂. These on-chip metal film resistors are laser-trimmed to accurate absolute values. The accuracy and temperature coefficient of these resistors are included in the gain accuracy and drift specifications of the INA2128.

The stability and temperature drift of the external gain setting resistor, R_G, also affects gain. R_G's contribution to gain accuracy and drift can be directly inferred from the gain equation (1). Low resistor values required for high gain can make wiring resistance important. Sockets add to the wiring resistance which will contribute additional gain error in gains of approximately 100 or greater.

DYNAMIC PERFORMANCE

The typical performance curve “Gain vs Frequency” shows that despite its low quiescent current, the INA2128 achieves wide bandwidth, even at high gain. This is due to its current-feedback topology. Settling time also remains excellent at high gain—see “Settling Time vs Gain.”

NOISE PERFORMANCE

The INA2128 provides very low noise in most applications. Low frequency noise is approximately 0.2μV_{PP} measured from 0.1 to 10Hz (G ≥ 100). This provides dramatically improved noise when compared to state-of-the-art chopper-stabilized amplifiers.

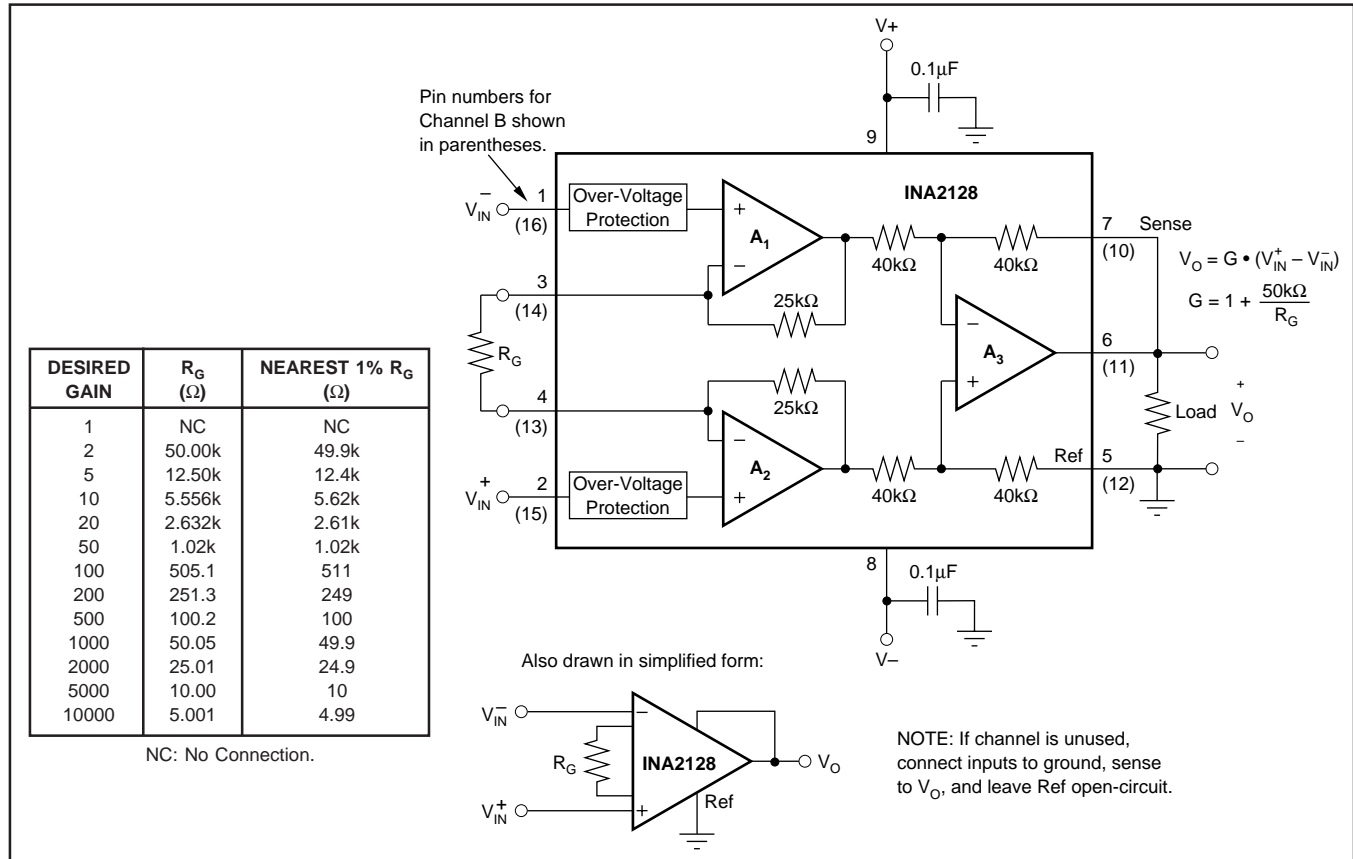

FIGURE 1. Basic Connections.

OFFSET TRIMMING

The INA2128 is laser-trimmed for low offset voltage and offset voltage drift. Most applications require no external offset adjustment. Figure 2 shows an optional circuit for trimming the output offset voltage. The voltage applied to Ref terminal is summed with the output. The op amp buffer provides low impedance at the Ref terminal to preserve good common-mode rejection.

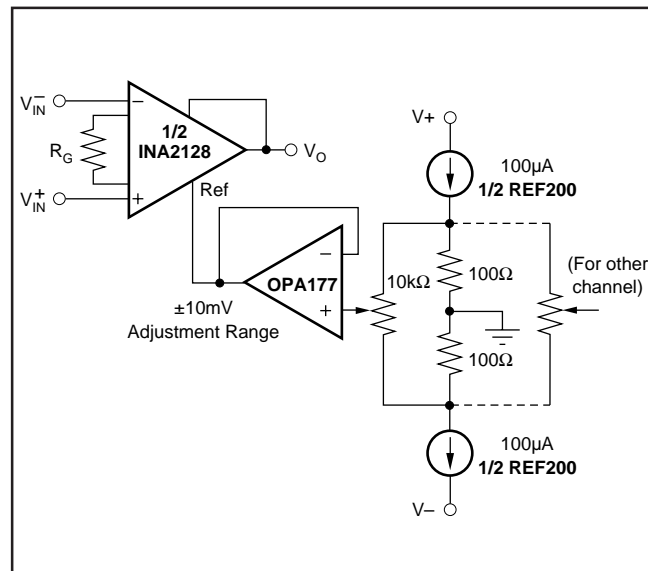

FIGURE 2. Optional Trimming of Output Offset Voltage.

INPUT BIAS CURRENT RETURN PATH

The input impedance of the INA2128 is extremely high—approximately $10^{10}\Omega$. However, a path must be provided for the input bias current of both inputs. This input bias current is approximately $\pm 2\text{nA}$. High input impedance means that this input bias current changes very little with varying input voltage.

Input circuitry must provide a path for this input bias current for proper operation. Figure 3 shows various provisions for an input bias current path. Without a bias current path, the inputs will float to a potential which exceeds the common-mode range of the INA2128 and the input amplifiers will saturate.

If the differential source resistance is low, the bias current return path can be connected to one input (see the thermocouple example in Figure 3). With higher source impedance, using two equal resistors provides a balanced input with possible advantages of lower input offset voltage due to bias current and better high-frequency common-mode rejection.

INPUT COMMON-MODE RANGE

The linear input voltage range of the input circuitry of the INA2128 is from approximately 1.4V below the positive supply voltage to 1.7V above the negative supply. As a differential input voltage causes the output voltage increase, however, the linear input range will be limited by the output

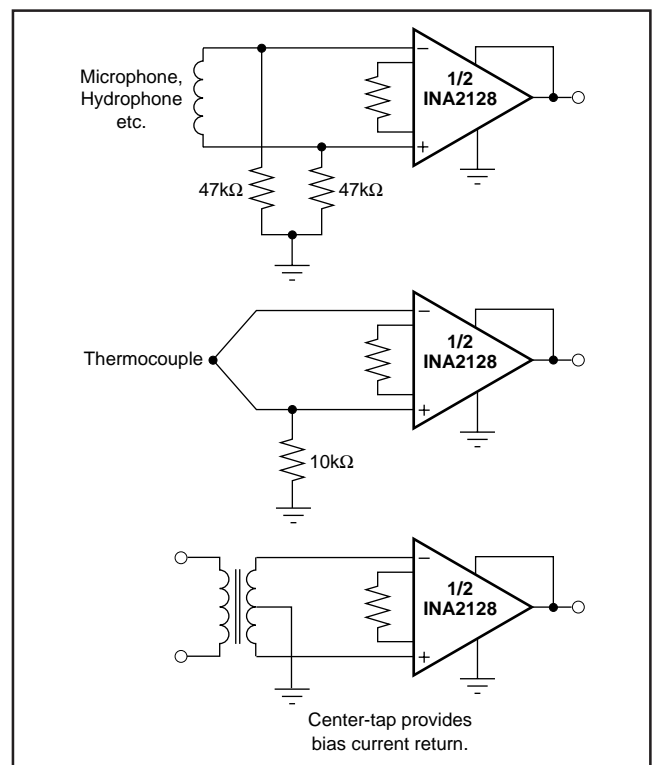

FIGURE 3. Providing an Input Common-Mode Current Path.

voltage swing of amplifiers A_1 and A_2 . So the linear common-mode input range is related to the output voltage of the complete amplifier. This behavior also depends on supply voltage—see performance curves “Input Common-Mode Range vs Output Voltage.”

Input-overload can produce an output voltage that appears normal. For example, if an input overload condition drives both input amplifiers to their positive output swing limit, the difference voltage measured by the output amplifier will be near zero. The output of the INA2128 will be near 0V even though both inputs are overloaded.

LOW VOLTAGE OPERATION

The INA2128 can be operated on power supplies as low as $\pm 2.25\text{V}$. Performance remains excellent with power supplies ranging from $\pm 2.25\text{V}$ to $\pm 18\text{V}$. Most parameters vary only slightly throughout this supply voltage range—see typical performance curves. Operation at very low supply voltage requires careful attention to assure that the input voltages remain within their linear range. Voltage swing requirements of internal nodes limit the input common-mode range with low power supply voltage. Typical performance curves, “Input Common-Mode Range vs Output Voltage,” show the range of linear operation for $\pm 15\text{V}$, $\pm 5\text{V}$, and $\pm 2.5\text{V}$ supplies.

PACKAGING INFORMATION

Orderable Device	Status ⁽¹⁾	Package Type	Package Drawing	Pins	Package Qty	Eco Plan ⁽²⁾	Lead/Ball Finish	MSL Peak Temp ⁽³⁾
INA2128U	ACTIVE	SOIC	DW	16	48	Green (RoHS & no Sb/Br)	CU NIPDAU	Level-3-260C-168 HR
INA2128U/1K	ACTIVE	SOIC	DW	16	1000	Green (RoHS & no Sb/Br)	CU NIPDAU	Level-3-260C-168 HR
INA2128U/1KE4	ACTIVE	SOIC	DW	16	1000	Green (RoHS & no Sb/Br)	CU NIPDAU	Level-3-260C-168 HR
INA2128UA	ACTIVE	SOIC	DW	16	48	Green (RoHS & no Sb/Br)	CU NIPDAU	Level-3-260C-168 HR
INA2128UA/1K	ACTIVE	SOIC	DW	16	1000	Green (RoHS & no Sb/Br)	CU NIPDAU	Level-3-260C-168 HR
INA2128UA/1KG4	ACTIVE	SOIC	DW	16	1000	Green (RoHS & no Sb/Br)	CU NIPDAU	Level-3-260C-168 HR
INA2128UAG4	ACTIVE	SOIC	DW	16	48	Green (RoHS & no Sb/Br)	CU NIPDAU	Level-3-260C-168 HR
INA2128UG4	ACTIVE	SOIC	DW	16	48	Green (RoHS & no Sb/Br)	CU NIPDAU	Level-3-260C-168 HR

⁽¹⁾ The marketing status values are defined as follows:

ACTIVE: Product device recommended for new designs.

LIFEBUY: TI has announced that the device will be discontinued, and a lifetime-buy period is in effect.

NRND: Not recommended for new designs. Device is in production to support existing customers, but TI does not recommend using this part in a new design.

PREVIEW: Device has been announced but is not in production. Samples may or may not be available.

OBSOLETE: TI has discontinued the production of the device.

⁽²⁾ Eco Plan - The planned eco-friendly classification: Pb-Free (RoHS), Pb-Free (RoHS Exempt), or Green (RoHS & no Sb/Br) - please check <http://www.ti.com/productcontent> for the latest availability information and additional product content details.

TBD: The Pb-Free/Green conversion plan has not been defined.

Pb-Free (RoHS): TI's terms "Lead-Free" or "Pb-Free" mean semiconductor products that are compatible with the current RoHS requirements for all 6 substances, including the requirement that lead not exceed 0.1% by weight in homogeneous materials. Where designed to be soldered at high temperatures, TI Pb-Free products are suitable for use in specified lead-free processes.

Pb-Free (RoHS Exempt): This component has a RoHS exemption for either 1) lead-based flip-chip solder bumps used between the die and package, or 2) lead-based die adhesive used between the die and leadframe. The component is otherwise considered Pb-Free (RoHS compatible) as defined above.

Green (RoHS & no Sb/Br): TI defines "Green" to mean Pb-Free (RoHS compatible), and free of Bromine (Br) and Antimony (Sb) based flame retardants (Br or Sb do not exceed 0.1% by weight in homogeneous material)

⁽³⁾ MSL, Peak Temp. -- The Moisture Sensitivity Level rating according to the JEDEC industry standard classifications, and peak solder temperature.

Important Information and Disclaimer: The information provided on this page represents TI's knowledge and belief as of the date that it is provided. TI bases its knowledge and belief on information provided by third parties, and makes no representation or warranty as to the accuracy of such information. Efforts are underway to better integrate information from third parties. TI has taken and continues to take reasonable steps to provide representative and accurate information but may not have conducted destructive testing or chemical analysis on incoming materials and chemicals. TI and TI suppliers consider certain information to be proprietary, and thus CAS numbers and other limited information may not be available for release.

In no event shall TI's liability arising out of such information exceed the total purchase price of the TI part(s) at issue in this document sold by TI to Customer on an annual basis.

TAPE AND REEL INFORMATION

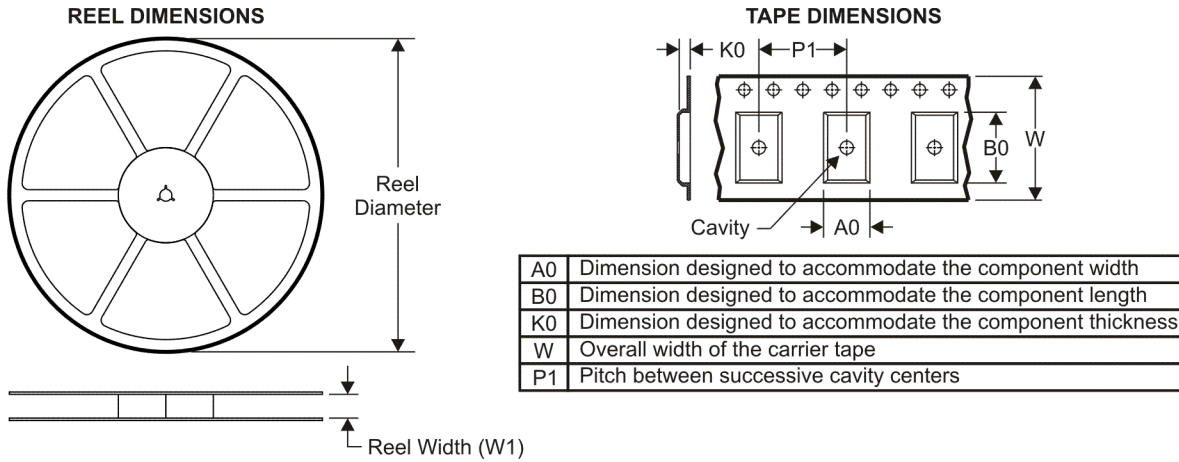

QUADRANT ASSIGNMENTS FOR PIN 1 ORIENTATION IN TAPE

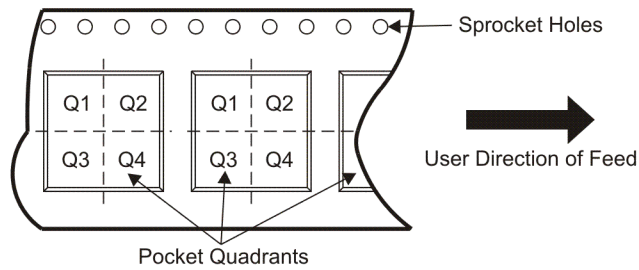

*All dimensions are nominal

Device	Package Type	Package Drawing	Pins	SPQ	Reel Diameter (mm)	Reel Width W1 (mm)	A0 (mm)	B0 (mm)	K0 (mm)	P1 (mm)	W (mm)	Pin1 Quadrant
INA2128U/1K	SOIC	DW	16	1000	330.0	16.4	10.85	10.8	2.7	12.0	16.0	Q1
INA2128UA/1K	SOIC	DW	16	1000	330.0	16.4	10.85	10.8	2.7	12.0	16.0	Q1

TAPE AND REEL BOX DIMENSIONS

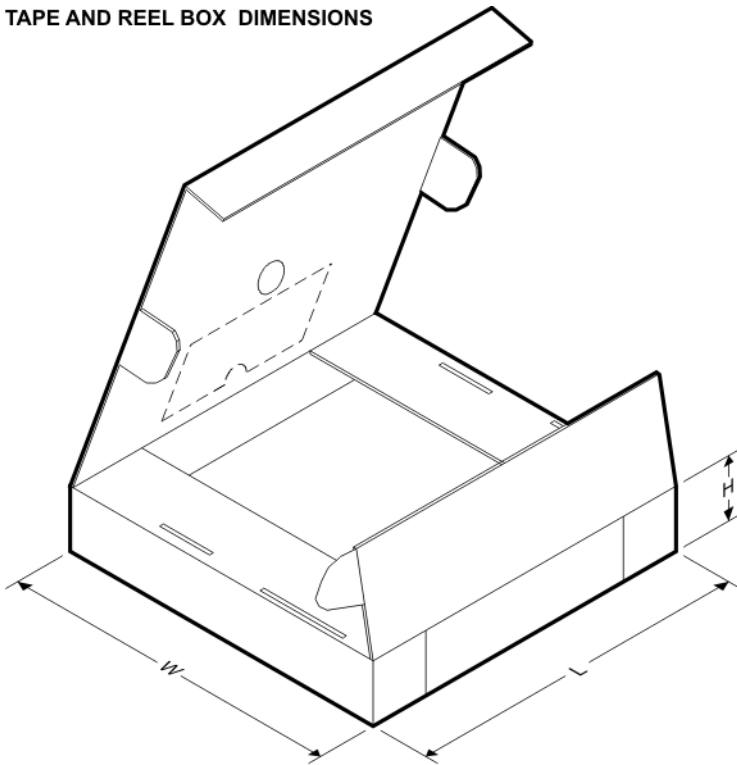

*All dimensions are nominal

Device	Package Type	Package Drawing	Pins	SPQ	Length (mm)	Width (mm)	Height (mm)
INA2128U/1K	SOIC	DW	16	1000	346.0	346.0	33.0
INA2128UA/1K	SOIC	DW	16	1000	346.0	346.0	33.0

DW (R-PDSO-G16)

PLASTIC SMALL-OUTLINE PACKAGE

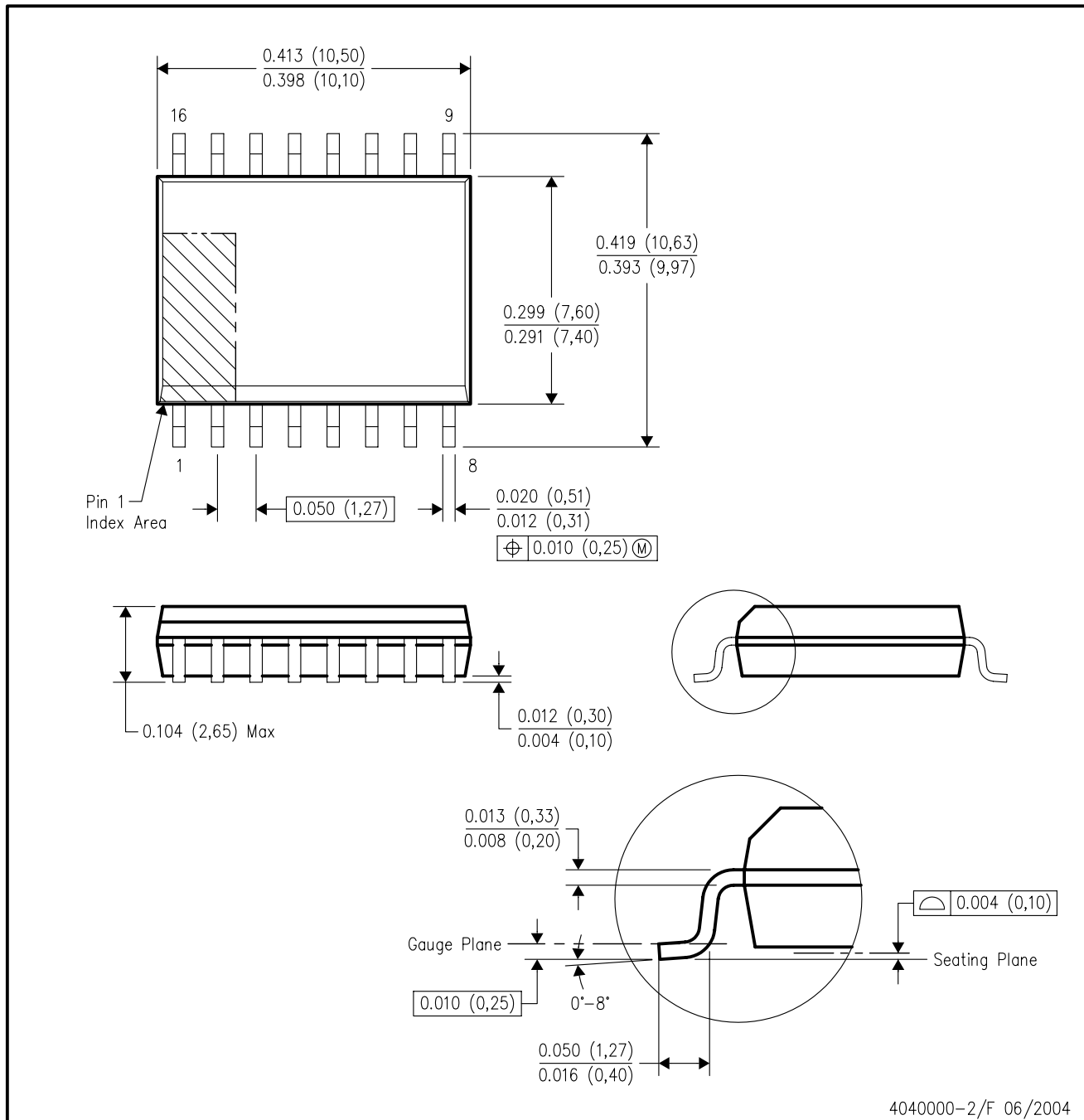

- NOTES:
- A. All linear dimensions are in inches (millimeters).
 - B. This drawing is subject to change without notice.
 - C. Body dimensions do not include mold flash or protrusion not to exceed 0.006 (0,15).
 - D. Falls within JEDEC MS-013 variation AA.

IMPORTANT NOTICE

Texas Instruments Incorporated and its subsidiaries (TI) reserve the right to make corrections, modifications, enhancements, improvements, and other changes to its products and services at any time and to discontinue any product or service without notice. Customers should obtain the latest relevant information before placing orders and should verify that such information is current and complete. All products are sold subject to TI's terms and conditions of sale supplied at the time of order acknowledgment.

TI warrants performance of its hardware products to the specifications applicable at the time of sale in accordance with TI's standard warranty. Testing and other quality control techniques are used to the extent TI deems necessary to support this warranty. Except where mandated by government requirements, testing of all parameters of each product is not necessarily performed.

TI assumes no liability for applications assistance or customer product design. Customers are responsible for their products and applications using TI components. To minimize the risks associated with customer products and applications, customers should provide adequate design and operating safeguards.

TI does not warrant or represent that any license, either express or implied, is granted under any TI patent right, copyright, mask work right, or other TI intellectual property right relating to any combination, machine, or process in which TI products or services are used. Information published by TI regarding third-party products or services does not constitute a license from TI to use such products or services or a warranty or endorsement thereof. Use of such information may require a license from a third party under the patents or other intellectual property of the third party, or a license from TI under the patents or other intellectual property of TI.

Reproduction of TI information in TI data books or data sheets is permissible only if reproduction is without alteration and is accompanied by all associated warranties, conditions, limitations, and notices. Reproduction of this information with alteration is an unfair and deceptive business practice. TI is not responsible or liable for such altered documentation. Information of third parties may be subject to additional restrictions.

Resale of TI products or services with statements different from or beyond the parameters stated by TI for that product or service voids all express and any implied warranties for the associated TI product or service and is an unfair and deceptive business practice. TI is not responsible or liable for any such statements.

TI products are not authorized for use in safety-critical applications (such as life support) where a failure of the TI product would reasonably be expected to cause severe personal injury or death, unless officers of the parties have executed an agreement specifically governing such use. Buyers represent that they have all necessary expertise in the safety and regulatory ramifications of their applications, and acknowledge and agree that they are solely responsible for all legal, regulatory and safety-related requirements concerning their products and any use of TI products in such safety-critical applications, notwithstanding any applications-related information or support that may be provided by TI. Further, Buyers must fully indemnify TI and its representatives against any damages arising out of the use of TI products in such safety-critical applications.

TI products are neither designed nor intended for use in military/aerospace applications or environments unless the TI products are specifically designated by TI as military-grade or "enhanced plastic." Only products designated by TI as military-grade meet military specifications. Buyers acknowledge and agree that any such use of TI products which TI has not designated as military-grade is solely at the Buyer's risk, and that they are solely responsible for compliance with all legal and regulatory requirements in connection with such use.

TI products are neither designed nor intended for use in automotive applications or environments unless the specific TI products are designated by TI as compliant with ISO/TS 16949 requirements. Buyers acknowledge and agree that, if they use any non-designated products in automotive applications, TI will not be responsible for any failure to meet such requirements.

Following are URLs where you can obtain information on other Texas Instruments products and application solutions:

Products

Amplifiers	amplifier.ti.com
Data Converters	dataconverter.ti.com
DSP	dsp.ti.com
Clocks and Timers	www.ti.com/clocks
Interface	interface.ti.com
Logic	logic.ti.com
Power Mgmt	power.ti.com
Microcontrollers	microcontroller.ti.com
RFID	www.ti-rfid.com
RF/IF and ZigBee® Solutions	www.ti.com/lprf

Applications

Audio	www.ti.com/audio
Automotive	www.ti.com/automotive
Broadband	www.ti.com/broadband
Digital Control	www.ti.com/digitalcontrol
Medical	www.ti.com/medical
Military	www.ti.com/military
Optical Networking	www.ti.com/opticalnetwork
Security	www.ti.com/security
Telephony	www.ti.com/telephony
Video & Imaging	www.ti.com/video
Wireless	www.ti.com/wireless

Mailing Address: Texas Instruments, Post Office Box 655303, Dallas, Texas 75265
Copyright © 2008, Texas Instruments Incorporated